

# QUANTM h120 Sanitary Pumps



FG series



HS series

## TECHNICAL SPECIFICATIONS

<b>Maximum Fluid Pressure</b>	5 bar
<b>Maximum Fluid Flow</b>	450 lpm
<b>Maximum Particle Size</b>	FG 6.35 mm HS 12.7 mm
<b>Environmental Temp Rating</b>	-18 to 40 °C
<b>Fluid Connection</b>	FG 65 mm DIN 11851 HS 50 mm DIN 11851
<b>Suction Lift</b>	Dry 4.0 m Wet 6.8 m
<b>Approvals*</b>	FDA CFR Title 21, EC 1935/2004, USP Class VI, ATEX
<b>Fluid Section Materials</b>	Food Grade Stainless 316 SST, High Sanitary 316L SST, Pharma Grade 316L SST
<b>Surface Finish Options</b>	FG 3.2 Ra, HS 0.8 Ra, PH 0,5 Ra, 3A 0,8 Ra
<b>Seat Options</b>	Stainless Steel
<b>Check Ball Options</b>	PTFE, Santoprene, FKM, Buna, Flapper
<b>Diaphragm Options</b>	2-piece PTFE, PTFE OM, Santoprene, Buna, FKM, EPDM OM
<b>Seals and Gasket Options</b>	PTFE, EPDM, FKM, Buna

\*Approvals are dependent on pump configuration build

## ELECTRICAL RATINGS

	RATED VOLTAGE	PHASE	HERTZ	CURRENT	PLUG TYPE	APPROVALS
<b>F2 motor</b>	230 V	1	50 Hz	15 A	NEMA L15-20	-
<b>F4 motor</b>	230 V	1	50 Hz	15 A	No Plug	ATEX

## PERFORMANCE

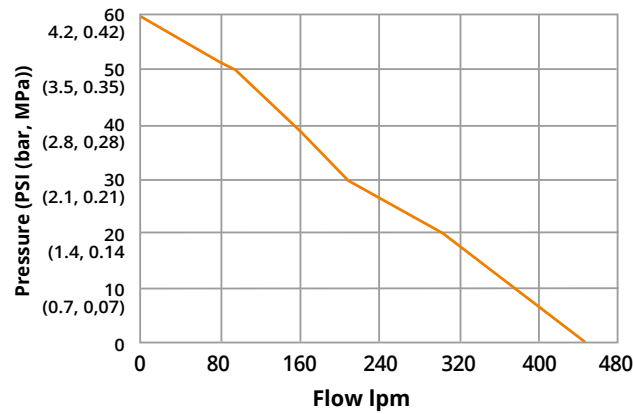

## FOOD GRADE HYGIENIC

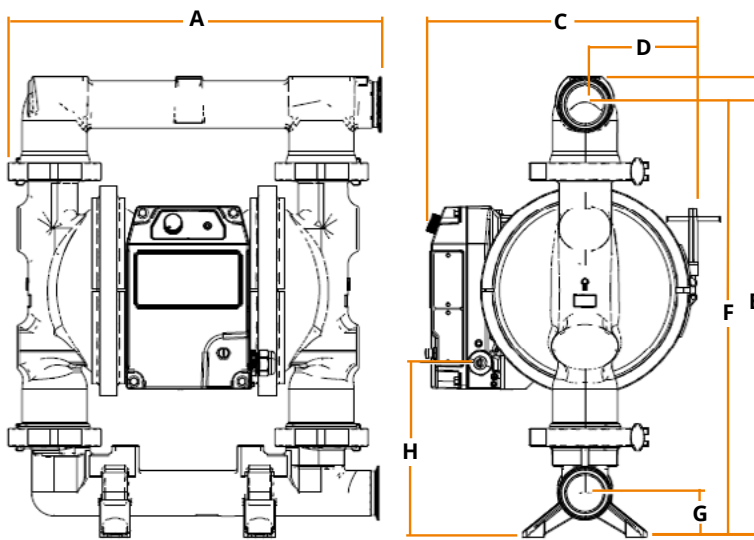

DIM	CM
A	53.52
B	---
C	38.81
D	16.08
E	65.91
F	61.98
G	6.35
H	24.94
J	15.88
K	15.88
<b>WEIGHT: 77.1 KG</b>	

## HIGH SANITARY, PHARMACEUTICAL, AND 3A HYGIENIC

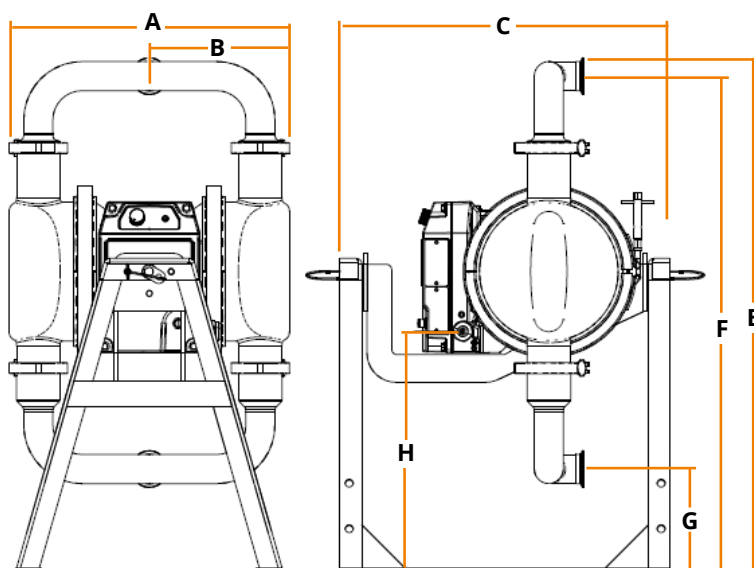

DIM	CM
A	49.02
B	24.51
C	37.82
D	16.08
E	89.69
F	86.49
G	18.01
H	40.89
J	41.15
K	33.02
<b>WEIGHT: 64.9 KG</b>	

### HOLLAND AIR PUMPS BV

DE SCHEPER 260  
NL 5688 HP OIRSCHOT  
THE NETHERLANDS

### PHONE

+31 (0)499 551 000

### EMAIL

INFO@HOLLANDAIRPUMPS.NL

### VAT

NL8033.13.123.B01

### ING BANK ACC

NL79 INGB 068 29 36 02

### ONLINE

WWW.HOLLANDAIRPUMPS.NL

### CHAMBER OF COMMERCE

ROTTERDAM 24.252.831