

QUANTM h30 Sanitary Pumps



FG series



HS series

TECHNICAL SPECIFICATIONS

Maximum Fluid Pressure	7 bar
Maximum Fluid Flow	115 lpm
Maximum Particle Size	FG 3.2 mm HS 20.7 mm
Environmental Temp Rating	-18 to 40 °C
Fluid Connection	FG 40 mm DIN 11851 HS 25 mm DIN 11851
Suction Lift	Dry 3.5 m Wet 6.8 m
Approvals*	FDA CFR Title 21, EC 1935/2004, USP Class VI, ATEX
Fluid Section Materials	Food Grade Stainless 316 SST, High Sanitary 316L SST, Pharma Grade 316L SST
Surface Finish Options	FG 3.2 Ra, HS 0.8 Ra, PH 0,5 Ra, 3A 0,8 Ra
Seat Options	Stainless Steel
Check Ball Options	PTFE, Santoprene, FKM, Buna, Flapper
Diaphragm Options	2-piece PTFE, PTFE OM, Santoprene, Buna, FKM, EPDM OM
Seals and Gasket Options	PTFE, EPDM, FKM, Buna

*Approvals are dependent on pump configuration build

ELECTRICAL RATINGS

	RATED VOLTAGE	PHASE	HERTZ	CURRENT	PLUG TYPE	APPROVALS
F2 motor	230 V	1	50 Hz	10 A	NEMA L15-15	-
F4 motor	230 V	1	50 Hz	10 A	No Plug	ATEX

PERFORMANCE & POWER

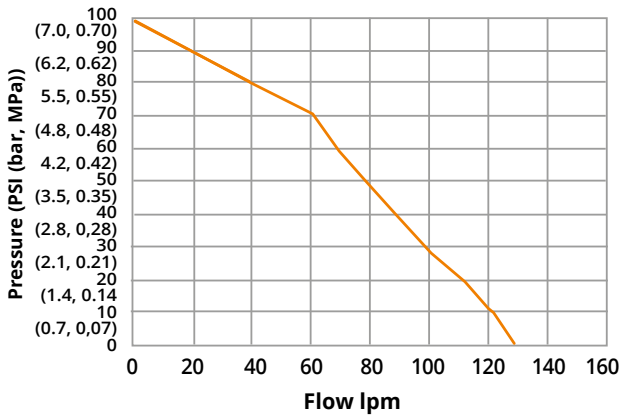

Q30 - POWER CURVES

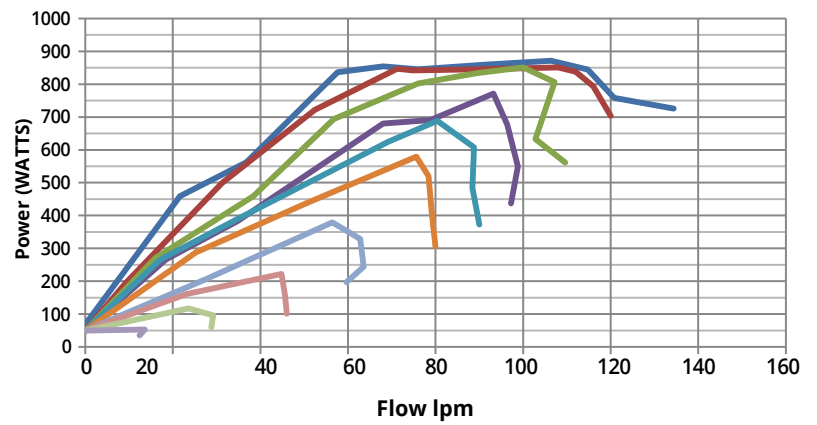

FOOD GRADE HYGIENIC

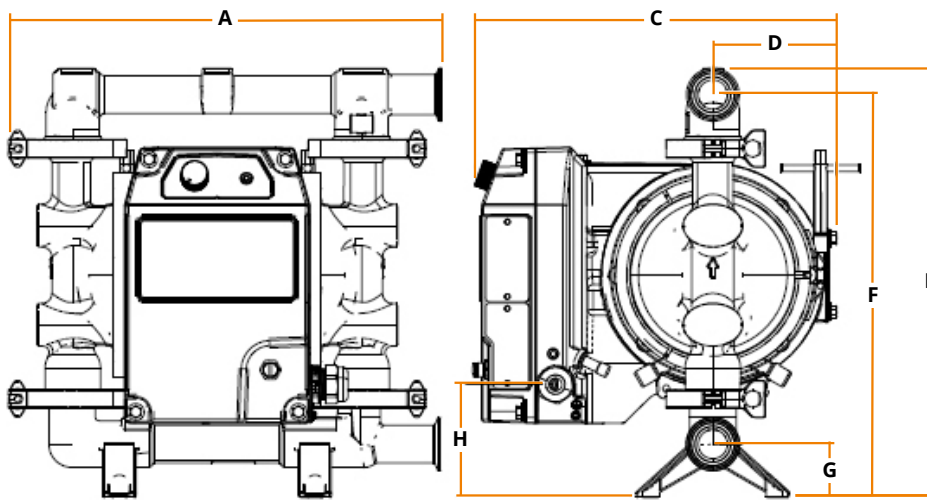

DIM	CM
A	41.40
B	---
C	34.54
D	11.81
E	40.90
F	38.40
G	5.08
H	10.77
J	12.70
K	18.67
WEIGHT: 39.9 KG	

HIGH SANITARY, PHARMACEUTICAL, AND 3A HYGIENIC

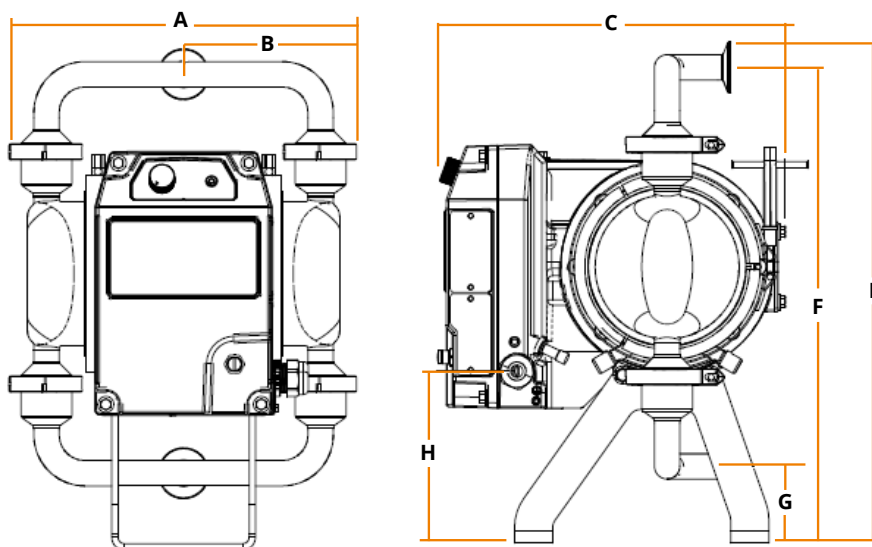

DIM	CM
A	34.80
B	17.40
C	33.66
D	11.61
E	49.35
F	46.81
G	7.04
H	15.75
J	10.16
K	21.59
WEIGHT: 34.9 KG	

HOLLAND AIR PUMPS BV

DE SCHEPER 260
NL 5688 HP OIRSCHOT
THE NETHERLANDS

PHONE

+31 (0)499 551 000

EMAIL

INFO@HOLLANDAIRPUMPS.NL

VAT

NL8033.13.123.B01

ING BANK ACC

NL79 INGB 068 29 36 02

ONLINE

WWW.HOLLANDAIRPUMPS.NL

CHAMBER OF COMMERCE

ROTTERDAM 24.252.831