

# QUANTM i120 Industrial Pumps



AL series



SST en HAS series



CP, PP en PV series

## TECHNICAL SPECIFICATIONS

<b>Maximum Fluid Pressure</b>	5 bar
<b>Maximum Fluid Flow</b>	450 lpm
<b>Maximum Particle Size</b>	6.35 mm
<b>Environmental Temp Rating</b>	-18 to 40 °C
<b>Fluid Connection</b>	AL, SST, CI 2.0 in BSPT(F) CP, PP, PV ANSI 150 2 NPS, DIN PN16 050-2 in, JIS 10k 50
<b>Suction Lift</b>	Dry 4.0 m Wet 6.8 m
<b>Approvals</b>	ATEX
<b>Fluid Section Materials</b>	Aluminium, Stainless Steel, Polypropylene, Conductive Polypropylene, PVDF, Hastelloy
<b>Seat Options</b>	Aluminium, Santoprene, Geolast, Hytrel, Stainless Steel, Buna, FKM
<b>Check Ball Options</b>	TPE, Santoprene, Geolast, Hytrel, PTFE, Buna, FKM, Stainless Steel, Acetal
<b>Diaphragm Options</b>	2-piece PTFE, PTFE OM, Santoprene, Buna, FKM, Geolast, Hytrel
<b>Seals and Gasket Options</b>	PTFE, Buna

## ELECTRICAL RATINGS

	RATED VOLTAGE	PHASE	HERTZ	CURRENT	PLUG TYPE	APPROVALS
<b>F2 motor</b>	230 V	1	50 Hz	15 A	NEMA L15-20	-
<b>F4 motor</b>	230 V	1	50 Hz	15 A	No Plug	ATEX

# PERFORMANCE

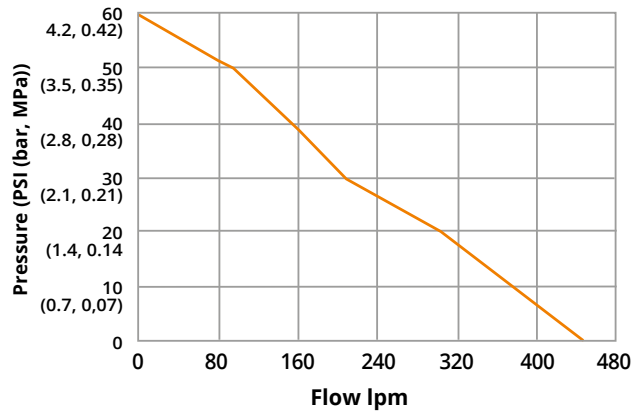

## ALUMINIUM PUMPS

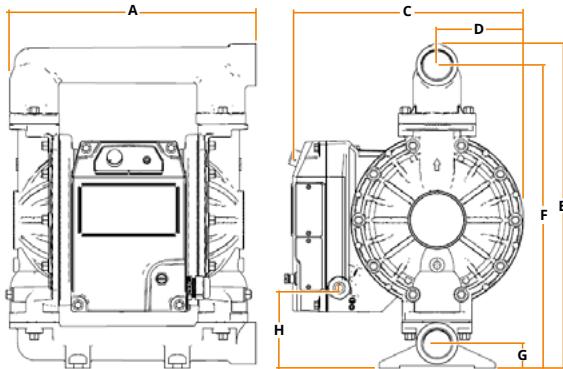

DIM	CM
A	44.45
B	<b>22.86</b>
C	<b>37.82</b>
D	15.88
E	59.94
F	55.63
G	5.08
H	5.08
J	15.24
K	15.24

**WEIGHT: 44.9 KG**

## STAINLESS STEEL, CAST IRON & HASTELLOY

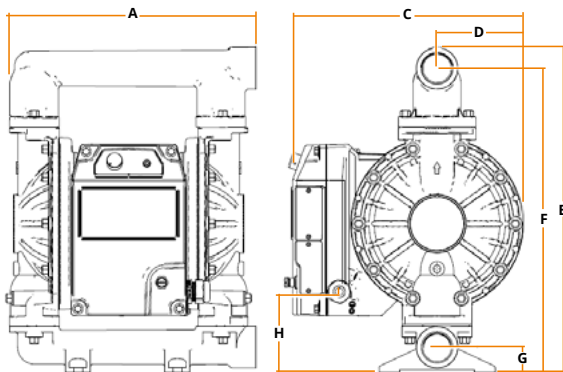

DIM	CM
A	46.05
B	23.88
C	37.82
D	15.88
E	66.90
F	62.97
G	6.35
H	22.89
J	15.24
K	15.24

**WEIGHT:**  
**SST** 73.5 KG  
**CI** 74.8 KG

## POLYPROPYLENE, CONDUCTIVE POLYPROPYLENE & PVDF

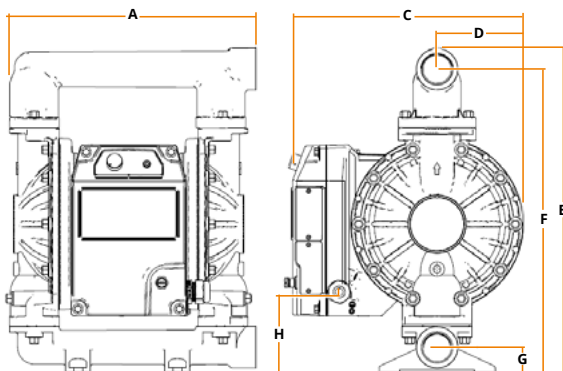

DIM	CM
A	50.04
B	<b>27.94</b>
C	<b>37.82</b>
D	15.88
E	65.28
F	57.66
G	8.89
H	19.13
J	15.24
K	15.24

**WEIGHT:**  
**PP, CP** 45.4 KG  
**PV** 53 KG

### HOLLAND AIR PUMPS BV

DE SCHEPER 260  
 NL 5688 HP OIRSCHOT  
 THE NETHERLANDS

### PHONE

+31 (0)499 551 000

### EMAIL

INFO@HOLLANDAIRPUMPS.NL

### VAT

NL8033.13.123.B01

### ING BANK ACC

NL79 INGB 068 29 36 02

### ONLINE

WWW.HOLLANDAIRPUMPS.NL

### CHAMBER OF COMMERCE

ROTTERDAM 24.252.831