

QUANTM i80 Industrial Pumps



AL series



SST en HAS series



CP, PP en PV series

TECHNICAL SPECIFICATIONS

Maximum Fluid Pressure	7 bar
Maximum Fluid Flow	300 lpm
Maximum Particle Size	4.8 mm
Environmental Temp Rating	-18 to 40 °C
Fluid Connection	AL, SST 1.5 in BSPT CP, PP, PV 1.5 in. ANSI/DIN
Suction Lift	Dry 4.0 m Wet 6.8 m
Approvals	ATEX
Fluid Section Materials	Aluminium, Stainless Steel, Polypropylene, Conductive Polypropylene, PVDF, Hastelloy
Seat Options	Aluminium, Santoprene, Geolast, Hytrel, Stainless Steel, Buna, FKM
Check Ball Options	TPE, Santoprene, Geolast, Hytrel, PTFE, Buna, FKM, Stainless Steel, Acetal
Diaphragm Options	2-piece PTFE, PTFE OM, Santoprene, Buna, FKM, Geolast, Hytrel
Seals and Gasket Options	PTFE, Buna

ELECTRICAL RATINGS

	RATED VOLTAGE	PHASE	HERTZ	CURRENT	PLUG TYPE	APPROVALS
F2 motor	230 V	1	50 Hz	15 A	NEMA L15-20	-
F4 motor	230 V	1	50 Hz	15 A	No Plug	ATEX

PERFORMANCE

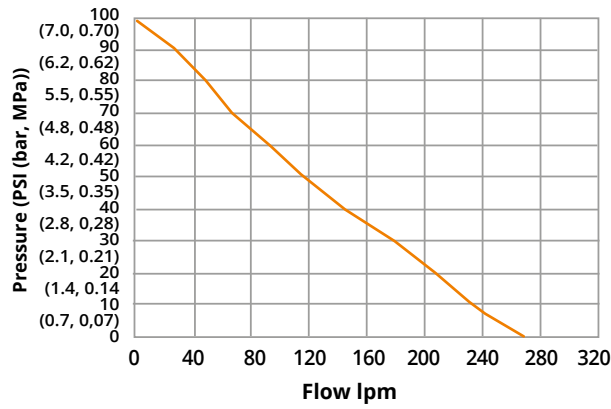

ALUMINIUM PUMPS

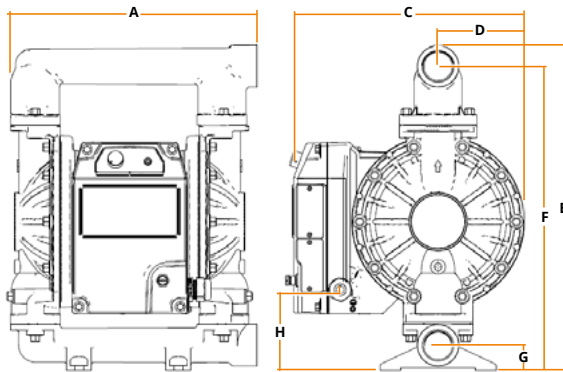

DIM	CM
A	38.28
C	38.28
D	13.13
E	49.78
F	46.48
G	3.81
H	11.56
J	15.24
K	15.24
WEIGHT: 32.2 KG	

STAINLESS STEEL & HASTELLOY

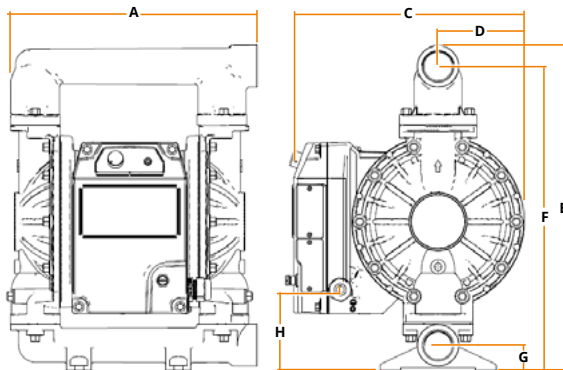

DIM	CM
A	40.89
C	35.18
D	13.23
E	48.18
F	45.09
G	3.66
H	11.56
J	15.24
K	15.24
WEIGHT: 50.8 KG	

POLYPROPYLENE, CONDUCTIVE POLYPROPYLENE & PVDF

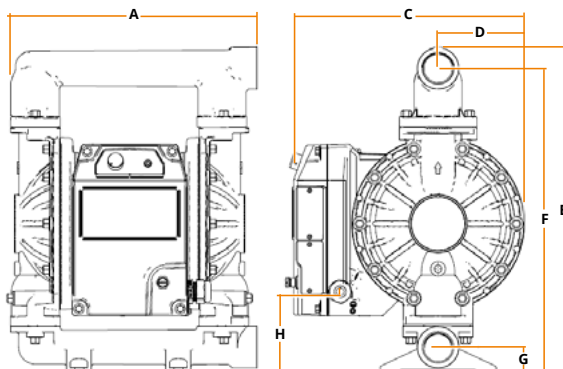

DIM	CM
A	44.70
C	35.23
D	13.28
E	55.88
F	49.02
G	7.62
H	14.86
J	15.24
K	15.24
WEIGHT:	
PP, CP	27.7 KG
PV	30.4 KG

HOLLAND AIR PUMPS BV

DE SCHEPER 260
NL 5688 HP OIRSCHOT
THE NETHERLANDS

PHONE
+31 (0)499 551 000

EMAIL
INFO@HOLLANDAIRPUMPS.NL

VAT
NL8033.13.123.B01

ING BANK ACC
NL79 INGB 068 29 36 02

ONLINE
WWW.HOLLANDAIRPUMPS.NL

CHAMBER OF COMMERCE
ROTTERDAM 24.252.831